

MAC Corporation

Little Giant Apartment Compactor

Quality by Design

The Little Giant Apartment Compactor is designed to fit in limited space applications such as the trash room of apartment and high-rise buildings. While smaller in size the Little Giant retains the same compaction ability as it's larger industrial cousins resulting in real operational cost savings.



This heavy duty compactor assembly is much stronger than others on the market. 3/16" side walls are reinforced with 1/4" thick structural tube framework and the packing ram face and compaction floor are 3/8" thick plate backed by structural steel channels and 3/8" thick contour shaped ribs. This extra rugged construction provides much longer service life even under extreme conditions.

Standard Features

Top Feed Hopper	2 Hopper Doors with Interlock Switches	Photo-eye Start
Single Side Container Ratchet	Remote Power Unit Factory Ready for 208-230-460V 3 phase Electrical Supply	
Key-lock Start Switch	Red Mushroom-head Stop Button	Reverse Push Button
Container Fullness Indicator Light	Adjustable Solid State Motor Starter Overload	Automatic Motor Starter Reset
UL Labeled Control System	Low DC Voltage Operator Controls	NEMA 12/13 Panel Box

The heart of the Little Giant compactor is the hydraulic power unit

Only top of the line, off the shelf components are utilized to deliver outstanding reliability and prevent “vendor lock in” for our customers.

Motor:	Baldor 208/230/460 volt 3 phase high efficiency. 220-230V single phase is available
Hydraulic pump:	Vickers ultra quiet vane type
Valve:	Yuken softshift
Fullness signaling pressure switch:	Barksdale
Hydraulic hose, connectors and fittings:	Weatherhead
Push buttons and switches:	General Electric / Allen Bradley
Motor starter and overload:	Eaton
PLC controller:	Eaton
Control transformer:	Oversize, 208/230/460 volt input with low DC secondary voltage for operator controls

Specifications and Dimensions

Mfr. Rating	.39 cubic yards
Industry Rating	.28 cubic yards
Clear Top Opening	22.5"L x 28"W
Hydraulic Cylinders	(2) 2.5" bore x 1.25" rod
Ram Penetration	4"
Packing Force	Normal: 15,600 lbs. Maximum Pack-Out: 17,700 lbs.
Ram Face PSI	Normal: 25.9 PSI Maximum: 29.4 PSI
Hydraulic Pressure	Normal: 1850 PSI Maximum: 2100 PSI
Cycle Time	14 seconds
Motor	5 H.P.
Pump	6 GPM vane
Frame Floor	3/8" plate
Frame Sides	3/16" plate
Breaker Bar	5" x 3" x 1/2" angle
Ram Face	3/8" plate
Ram Floor	3/8" plate
Ram Top	3/16" plate
Ram Sides	3/16" plate
Weight	1800 lbs. (does not include remote power unit)

Little Giant Apartment Compactor with Optional 2YD Front Load Container

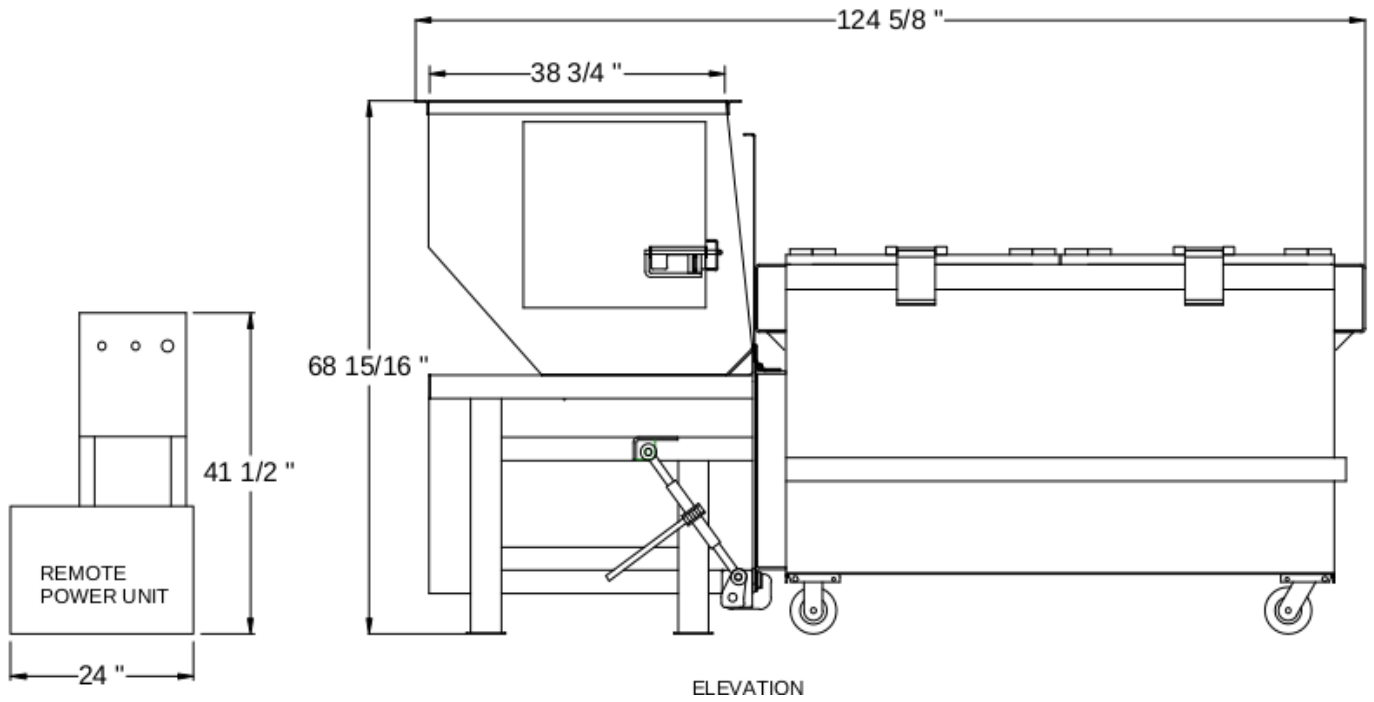
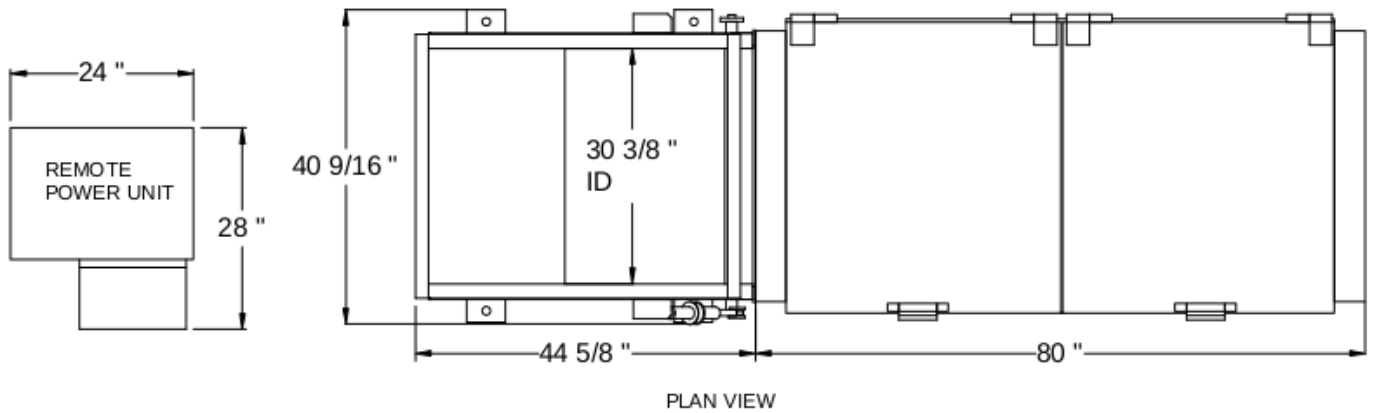

4717 Massachusetts Avenue
Indianapolis, Indiana
317-545-3341
800-447-5205
Fax: 317-545-8760